



Packaged INVERTER Range



Thank you for placing your confidence in S&P by buying this product. It has been manufactured following current technical safety regulations and in compliance with EC standards.

Please read this instruction booklet carefully before installing or starting up the product. It contains important information on personal and user safety measures to be followed while installing, using and carrying out maintenance work on the equipment. Once the product has been installed, please hand this booklet to the end user.

Check that the apparatus is in perfect condition while unpacking. Any fault or damage caused in origin is covered by the S&P guarantee. Please make sure that the apparatus coincides with the product you have ordered and that the details on the characteristics plate fulfil your requirements.

Transport and Handling

1. The packaging used for this apparatus has been designed to support normal transporting conditions. The apparatus must always be transported in its original packaging as not doing so could deform or damage the product.
2. The product should be stored in a dry place in its original packaging, protected from dust and dirt until it is installed in its final location. Do not accept delivery if the apparatus is not in its original packaging or shows clear signs of having been manipulated in any way.
3. Do not place heavy weights on the packed product and avoid knocking or dropping it.
4. When handling heavy products, adequate lifting equipment should be used to avoid harming people or damaging the product itself.
5. Never lift a product by pulling it by the wires or terminal/control enclosure. Likewise, no pressure should be applied on the impeller, shutter or spigots while handling the product.

GENERAL

6. The Packaged Inverter range comprises of single-phase (1PH) in, three-phase out (3PH) Variable Frequency Inverters specifically intended to control S&P 3PH 230V/400V fans.

Specification

7. The Inverter control is designed for continuous operation with the maximum rated current load, (10A or 16A, depending on version) on single phase 230 Volts ~ 50Hz supply.
8. The normal equipment temperature range is -10°C to +40°C.
9. The normal equipment humidity range is 20% RH to 90% RH.

10. The Inverter is not suitable for positioning where corrosive gas, oil, mist etc. are present.
11. The unit meets the EMC requirements of EN 61000-3-3:2015 and EN 61000-3-2:2015
12. The control is housed in an enclosure that is suitable for the current rating and is IP54 rated.

Important Information for the Safety of Installers and Users

13. Installation must only be carried out by qualified persons.
14. Make sure that the installation complies with each country's current mechanical and electrical norms.
15. Once ready to use, the apparatus must fulfil the following standards:
 - a. Standard for Low Voltage Installations 2006/95/CE
 - b. Machinery Standard 2006/42/CE
 - c. Standard for Electromagnetic Compatibility 2004/108/CE
16. Any area in or around a machine, where the presence of people can cause situations of danger for their safety or health, can be considered a high risk area.
17. This apparatus must not be used in explosive or corrosive atmospheres.
18. If an Inverter is required for working in the previously stated conditions, consult the S&P Technical Department.
19. If the apparatus is going to be used in atmospheres with over 90% relative humidity, consult the S&P Technical Department first.

Safety During Installation

20. When installing the Inverter, make sure that all the fittings are in place and that the structure which supports it is resistant enough to bear its weight at full functioning power.
21. Before manipulating the apparatus, make sure the mains supply is disconnected, even if the Inverter is switched off.
22. Check that the mains supply voltage and frequency values coincide with the stipulations on the characteristics plate.
23. Follow the connections diagram(s) for the electrical connections.
24. An earth connection is necessary, check that it is correctly connected and that adequate thermal and overloading protection has been connected and adjusted to the corresponding limits – please refer to note #35.

Mechanical Installation

25. The Inverter is intended to be supplied ONLY with a corresponding S&P three-phase ventilation fan. Check that the size and the speed of the fan can be safely controlled by this Inverter.
26. Install the Inverter in a dry sheltered position.

27. Leave an air space of not less than 150mm around the controller to allow cooling air to flow freely. Leave an additional gap in front of the Inverter to allow for access during installation/wiring/maintenance. Do not install in close proximity to other heat sources. The maximum ambient temperature for the controller must not exceed 40°C. The maximum humidity for the controller must not exceed 90%R.H.
28. The product should be vertically mounted only. In this orientation it is suitable for fitment onto a suitable supportive structure and secured through the 4 fixing holes provided.

Electrical Installation of the Inverter to a Corresponding “Packaged” S&P Fan

WARNING!

29. Mains voltage is present. It is the responsibility of the user to ensure compliance with the Health and Safety at Work Act, 1974.

CAUTION

30. Isolate mains supply before connecting.
31. This unit must be earthed.
32. All electrical connections should be made by a qualified electrician.
33. All wiring must be in accordance with current wiring regulations.
34. The apparatus should be provided with a separate suitably rated double pole isolator or switch.
35. The maximum input current values and recommended cable sizes for each Inverter type are shown in table 1 below.

Table 1.

Inverter Model	Maximum Input Current	Recommended Cable Sizes	
		Input Cable	Output Cable
DIG VFD 1PH>3PH 2.2kW 10A	32 A	4 mm ²	4 mm ²
DIG VFD 1PH>3PH 3.7kW 16A	32 A	4 mm ²	4 mm ²

36. The cable between the Inverter and fan should be a screened type.
37. The Inverter is suitable as supplied for connection to the fan with up to a 25m long connection cable. Installations in excess of this MAX. 25m CABLE LENGTH distance and up to 50m should be fitted also with an EMC Filter (not supplied). In the uncommon occurrence that the cable length exceeds 50m, a Choke is also required.

In Summary

- Fan plus Inverter Pack as supplied – MAX. CABLE LENGTH 25m
- Fan plus Inverter Pack + EMC Filter – MAX. CABLE LENGTH 50m
- Fan plus Inverter Pack + EMC Filter + Choke – CABLE LENGTH ABOVE 50m

Wiring Installation

38. THE THREE-PHASE FAN TO WHICH THE INVERTER IS TO BE CONNECTED HAS BEEN CONFIGURED TO ACCEPT A 230V 3-PH SUPPLY, NOT A 400V SUPPLY – DO NOT RE-CONFIGURE THE FAN TO ACCEPT A 400V SUPPLY!

39. Check that the power supply matches that on the Inverter rating plate.

40. The connections must be as shown in the wiring diagram on page 6 of this booklet.

41. All cable entries provided should be used. Any left unused should be blanked and left in a safe condition.

42. Remove the front cover of the controller from the base by removing the cover fixing screws. This provides access to the earth terminals which are located on the control circuit board.

NOTE – When removing the front cover, take great care not to damage the ribbon cable which connects the display to the circuit board which is fixed to the base. The ribbon cable's plug can be temporarily unplugged from the socket whilst the earth connections are being made.

43. When the earth connections have been made, re-attach the ribbon cable plug and then re-position the front cover and replace the fixing screws.

IMPORTANT – RISK OF DAMAGE! ENSURE THAT THE PLUG IS TIGHTLY SECURED TO THE SOCKET!

NOTE – When replacing the front cover, ensure that the seal is correctly positioned.

44. To access the other terminals, the front panel of the controller can be removed by firstly removing the panel fixing screws.

45. All cable entries provided should be used. Any left unused should be blanked and left in a safe condition.

46. Remove the front panel of the enclosure by removing the panel fixing screws. This provides access to the control circuit board terminals that are inside the enclosure. Replace the panel when the wiring connections have been made, ensuring that the seal is correctly positioned.

47. Check that the unit mountings and electrical connections are secure and in accordance with the applicable wiring diagram on page 6 of this instruction booklet.

48. For wiring diagrams of other schemes, please contact S&P.

49. IF IN DOUBT, ASK!

WIRING DIAGRAM (SINGLE PHASE 230V ~ 50Hz MAINS SUPPLY)

L – Supply Live 230V ~ 50Hz

N – Supply Neutral

E – Earth

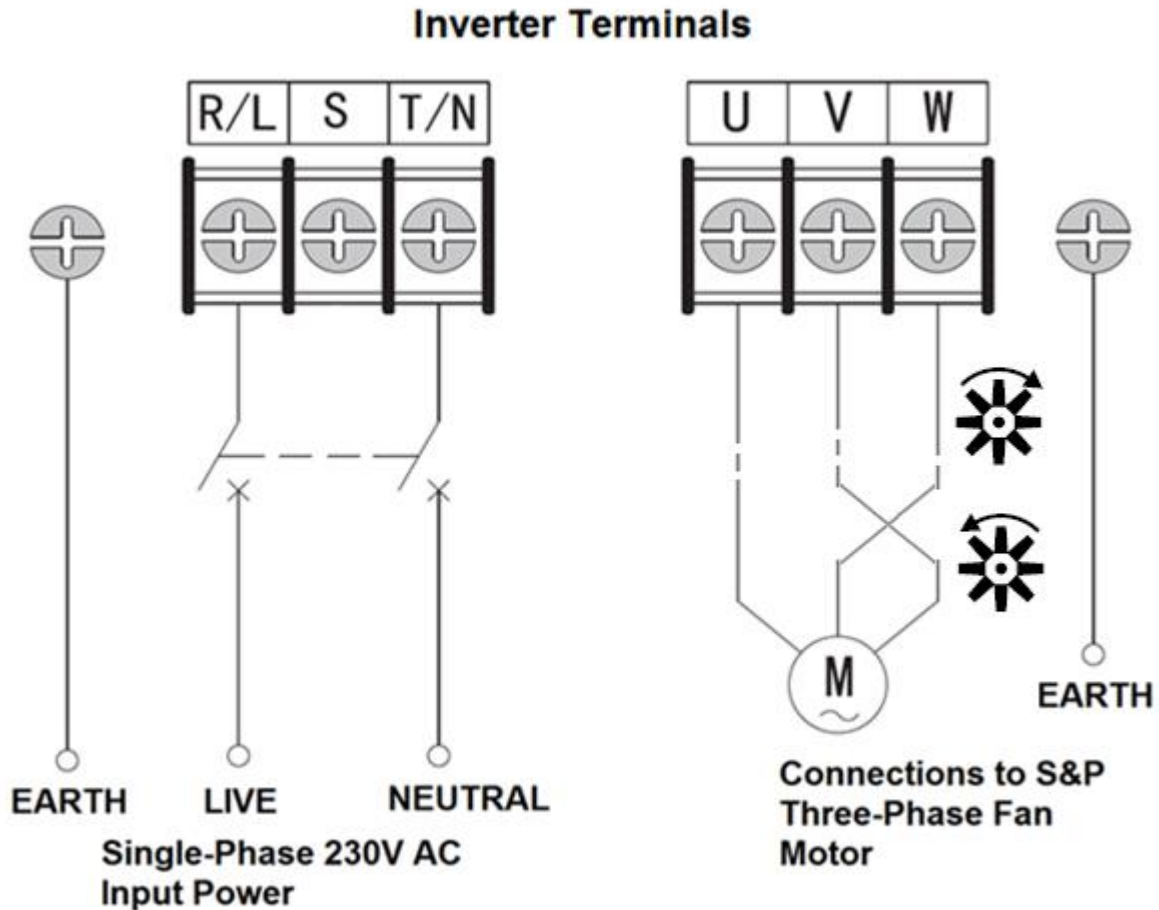

IMPORTANT NOTE TO INSTALLERS!

THE PACKAGED 3-PHASE FAN SUPPLIED WITH THIS INVERTER HAS BEEN CONFIGURED TO ACCEPT A 3-PH 230V SUPPLY, NOT A 400V SUPPLY - IT IS ESSENTIAL THAT THE FAN IS **NOT** RE-CONFIGURED.

IF IN DOUBT, ASK!

Set-Up and Initial Start-Up

50. The impedance overload protection parameter varies depending on the type of fan that the Inverter is being connected to and this parameter has been factory-configured in order to allow the Inverter to safely control and to provide overload protection ONLY to the packaged fan with which it has been supplied.

The Inverter must ONLY be connected to the corresponding packaged fan with which it has been supplied.

a. KeyPad

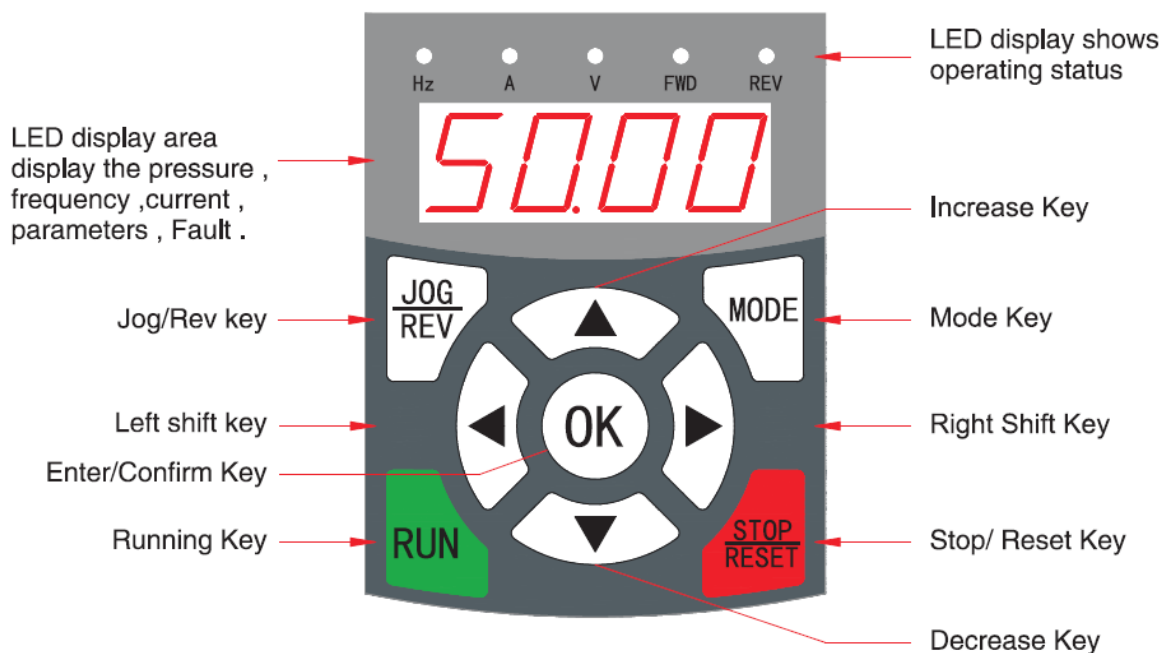



Fig. 1 Operation Pad Diagram



51. Pre-starting up checks – before starting up the fan, ensure that:
- The apparatus is well secured and that the electrical connections have been carried out correctly.
 - No loose material or fitting remains can be sucked up by the ventilator. If the ventilator has been mounted in a duct, make sure it is clear of loose material.
 - The earth fittings are adequately connected.
 - The electrical safety devices are correctly connected, adequately adjusted and ready for use.
 - The Inverter enclosure and electrical cable glands are correctly sealed and water-tight.

52. When starting up the product, ensure that:
- The impeller turns in the correct direction. If the impeller rotates in the wrong direction then press the STOP/RESET key immediately.

IF THE IMPELLER ROTATES IN THE WRONG DIRECTION THEN THE INVERTER/FAN MUST BE ISOLATED FROM THE MAINS SUPPLY AND ANY 2 PHASES BETWEEN THE INVERTER AND FAN THEN REVERSED BEFORE RE-STARTING.

- There are no abnormal vibrations.
 - If any of the electrical safety devices blow, the apparatus must be quickly disconnected from the mains supply.
 - The whole installation should be carefully checked before trying to start-up the fan again.
53. Switch on the control by pressing the "RUN" Key. The fan will start.
54. The Inverter has been factory set to accelerate the fan speed to 100% (50Hz) Inverter output in 40 seconds. The Inverter display will show the climbing frequency output from 0 to 50Hz over a 40 second period of time. When the fan has reached its maximum speed the frequency count on the display will stop counting at 50.00.
55. When running, adjust the frequency output with the   keys until the required fan duty point has been reached. Holding the keys down will speed-up the frequency change. For a more accurate frequency change (to fine-tune the Inverter output/fan speed), press and release the keys quickly rather than holding them down.
56. To stop the fan, press the STOP/RESET key. The fan will decelerate over a period of 40 seconds until it stops.
57. When "RUN" is pressed again to re-start the fan, the fan will accelerate to the speed defined by the frequency output previously set (in #55, above). When the fan has reached the speed the frequency count on the display will stop counting at the previously defined duty point frequency output (in #55, above).

Operating Instructions

58. Switch on the control by pressing the "RUN" Key. The fan will start.
59. The Inverter display will show the climbing frequency output from 0 to the defined duty point frequency. When the fan has reached its set speed the frequency count on the display will stop counting at the corresponding frequency output value.
60. When running, the frequency output can be adjusted with the   keys until the required fan speed is been reached. Holding the keys down will speed-up the frequency change. For a more accurate frequency change (to fine-tune the Inverter output/fan speed), press and release the keys quickly rather than holding them down.
61. To stop the fan, press the STOP/RESET key. The fan will stop.

62. If a fan failure is detected by current overload then the Inverter will shut down the fan. If this occurs then “OL3” will be displayed.

Troubleshooting

63. If after the fan has been running for some time there is a fault condition, then the reason for over-current must be investigated and corrected prior to re-energising.

Recycling

64. EEC Standards, together with the responsibility we should assume with future generations in mind, oblige us to recycle all the materials we can. Therefore, please deposit all left-over material and packaging in their corresponding recycling containers and hand in the replaced machines to the nearest handler of this type of waste product.

65. If you have any queries about S&P products, please contact our after-sales service at your local S&P dealer. If in doubt, please visit our website at www.solerpalau.co.uk

EC DECLARATION OF CONFORMITY

Herewith we declare that the fan/control designated below, on the basis of its design and construction in the form brought onto the market by us is, in accordance with the relevant EC Council Directives on Electromagnetic Compatibility. If alterations are made to the apparatus without prior consultations with us, this declaration becomes invalid. We further declare that the equipment identified below may be intended to be assembled with other equipment/machines to constitute machinery, which shall not be put into service until the assembled machinery has been declared in conformity with the provisions of these relevant EC Council Directives.

DESIGNATION OF EQUIPMENT

Relevant EC Council Directives, Electromagnetic Compatibility Directive 2014/30/EU

GUARANTEE

S&P Limited Warranty 36 (THIRTY SIX) MONTH PRODUCT WARRANTY

S&P UK Ventilation Systems Limited warrants that the S&P UK DIGITAL INVERTER will be free from defective materials and workmanship for the period of 36 (thirty six) months from the date of original purchase. In the event that we find any part is defective the product will be repaired or at the company's discretion, replaced without charge provided that the product has been installed in accordance with the enclosed instructions and all applicable standards and national and local building standards.

IF CLAIMING UNDER WARRANTY

Please return the completed product, carriage paid, to your local authorized distributor. All returns must be accompanied by a valid Invoice of Sale. All returns must be clearly marked "Warranty Claim", with an accompanying description stating the nature of the fault.

THE FOLLOWING WARRANTIES DO NOT APPLY

Damages resulting from improper wiring or installation.
Damages resulting when using the fan/control with fans/motors/controls/sensors other than those supplied and manufactured by the S&P Group of Companies.
Removal or alteration of the S&P data plate label.

WARRANTY VALIDATION

The end user must keep a copy of the Invoice of Sale to verify a purchase date.



S&P UK Ventilation Systems Ltd.

S&P House, Wentworth Road, Ransomes Europark,
Ipswich, Suffolk, IP3 9SW.

Tel. 08454 700 074 · Fax 08454 700 075

sales.uk@solerpalau.com & technical.uk@solerpalau.com

www.solerpalau.co.uk

REV02