

FD-C Series



Circular Single Blade Externally Resettable Combination Fire and Volume Control Damper

- ES classified fire dampers with reduced smoke leakage characteristics (BS EN 1366-2)
- Aerodynamically Air Control tested to BS EN 1751
- Tested and assessed installation methods in differing supporting constructions (BS EN 1366-2)
- Integrated volume control capability
- Replaceable fusible link from outside of the ductwork
- Commissioning friendly
- External blade position indicator
- Damper casing sizes and tolerances conform to BS EN 1506



MANUFACTURERS OF AIR, FIRE AND SMOKE CONTROL PRODUCTS



FD-C Series

Single Blade Circular Fire Dampers – Introduction



The FD-C Series

The FD-C Manual Operation Single Blade Fire Damper with volume control facility has been designed specifically for installations where space is at a premium.

The testing and resetting of the damper and thermal fuse external of the duct allows for ease of commissioning and maintenance. NB: Access panels may be required to comply with DW145 G.3.1.5.

The installation plate, with its engineered installation perforations, acts as a template to allow the marking of the fixing positions on the surface structure to which the plate will be affixed, allowing for a quick and efficient install.

Introduction

What is a fire damper and why might they be needed?

The FD-C Series Single Blade Circular Fire Damper is designed to stop the spread of fire through ducts, walls, floors and ceilings.

The product range has many features and options to meet the requirements of specifiers, contractors, local and national authorities. Dampers are available to suit both low/medium and high velocity applications.

What are the 'E' and 'ES' classifications?

To achieve the classifications to EN13501-3, fire dampers and fire and smoke dampers shall be tested to EN1366-2 and a 300Pa pressure difference is applied across the damper. During the fire test period, the integrity of the seal between the damper and the structure shall not have any gaps larger than 150mm x 6mm. There shall not be any sustained flaming. The largest size of damper to be manufactured for sale as a single section shall be fire tested.

E = Integrity

The maximum leakage permissible at 300Pa corrected to 20°C is 360m³/hr/m² (100 l/s/m²) throughout the fire test period.

ES = Integrity with Smoke Leakage Performance

The maximum leakage permissible at 300Pa corrected to 20°C is 200m³/hr/m² (55.5 l/s/m²) at ambient prior to the fire test and throughout the fire test period. In addition, for the ES classification to be attained, the smallest damper must also meet the 200m³/hr/m² maximum leakage with a 300Pa pressure across the damper. (This is equivalent to just 0.55 l/s on a 100x100 damper)

Fire dampers should be installed as tested.

Some applications (fan off) allow the use of tests undertaken to BS 476-20/22 and this is also allowed worldwide in areas outside of the EU. Test reports showing testing to EN 1366-2 should be acceptable to meet the requirements of BS 476-20/22, but the reverse is definitely not the case and no classifications are available.

However, as a word of caution, in whichever case, the correct model must be selected, to match fire resistance time with installation method and with the supporting construction (wall or floor).

BSB have a policy of continued testing and product certification to try and provide as broad a number of installation methods as possible.

BSB also follow regulation and standards development very carefully to provide input on changes and to be able to pass on relevant information to designers, specifiers, building control authorities (BCA's) and installers.

The FD-C Series Range

The BSB FD-C series is available in the following case diameters:

- FD-C100 - 100mm diameter
- FD-C125 - 125mm diameter
- FD-C150 - 150mm diameter
- FD-C160 - 160mm diameter
- FD-C200 - 200mm diameter
- FD-C250 - 250mm diameter
- FD-C300 - 300mm diameter
- FD-C315 - 315mm diameter

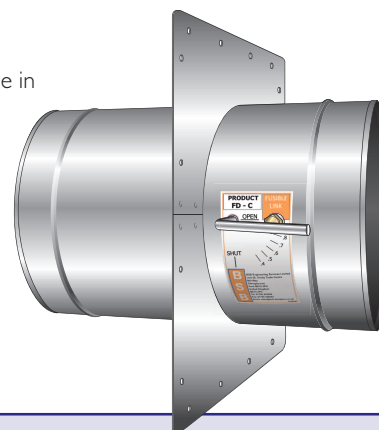

Testing and Conformities

Tested to EN1366-2

See installation details (Pages 6-11) for full details.

Tested and achieved classification to:

ES Classification (BS EN 1366-2/BS EN 13501-3)

- BSB FD-C fitted with Installation Plate
 - ES120 - Blockwork/Masonry wall
 - ES90 - Dry Partition wall
 - ES120 - Concrete floor

FD-C Blade leakage (BS EN 1751)

- Class 2

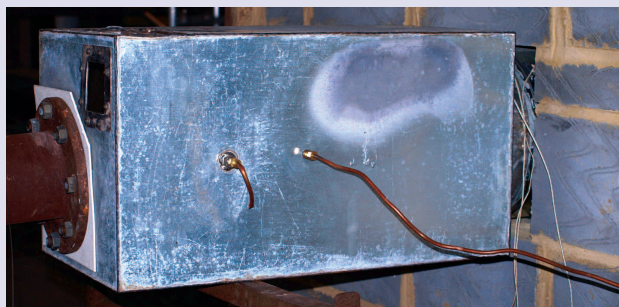

FD-C Features and Benefits

- Tested and certified installation variants of the FD-C are available for blockwork, dry wall and concrete floors.
- All BSB tested installation methods give at least a E90 classification.

Weight Chart (kg approx.)

Nom. Dia. (mm)	250mm no inst. plate	320mm with inst. plate
100	0.7	1.1
125	0.8	1.5
150	1.1	1.7
160	1.2	1.8
200	1.6	2.4
250	2.4	3.4
300	3.3	4.6
315	3.6	5.0

Case

Galvanised mild steel to BS EN 10346 DX 51D Z275
 0.6mm thick for 100mm dia. to 250mm dia.
 0.7mm thick for 300mm dia. to 315mm dia.
 Damper casing conforms to BS EN 1506.

Fusible Link

Fusible link externally replaceable rated at 72°C has been designed to alleviate possible linear creep of the solder joint. The thermal link is screwed into position via the 12.5mm diameter brass holder activating the locking assembly from outside the case in any position from fully open to fully closed, allowing air balance during the commissioning of the ducted system.

Handle

The handle is a 8mm dia. preformed 400 series ferretic stainless steel rod that allows the setting of the damper to any set point or fully open position. The blade angle is shown via the graduated affixed label.

Installation Plate

The optional installation plate allows the damper to be fixed into place from one side only with no infill material being required. Use either of the two appropriate 5mm dia. corner fixing holes and all of the 5mm dia. mid span fixing holes to secure the plate into position.
 (Note: Option without installation plate is not CE marked)

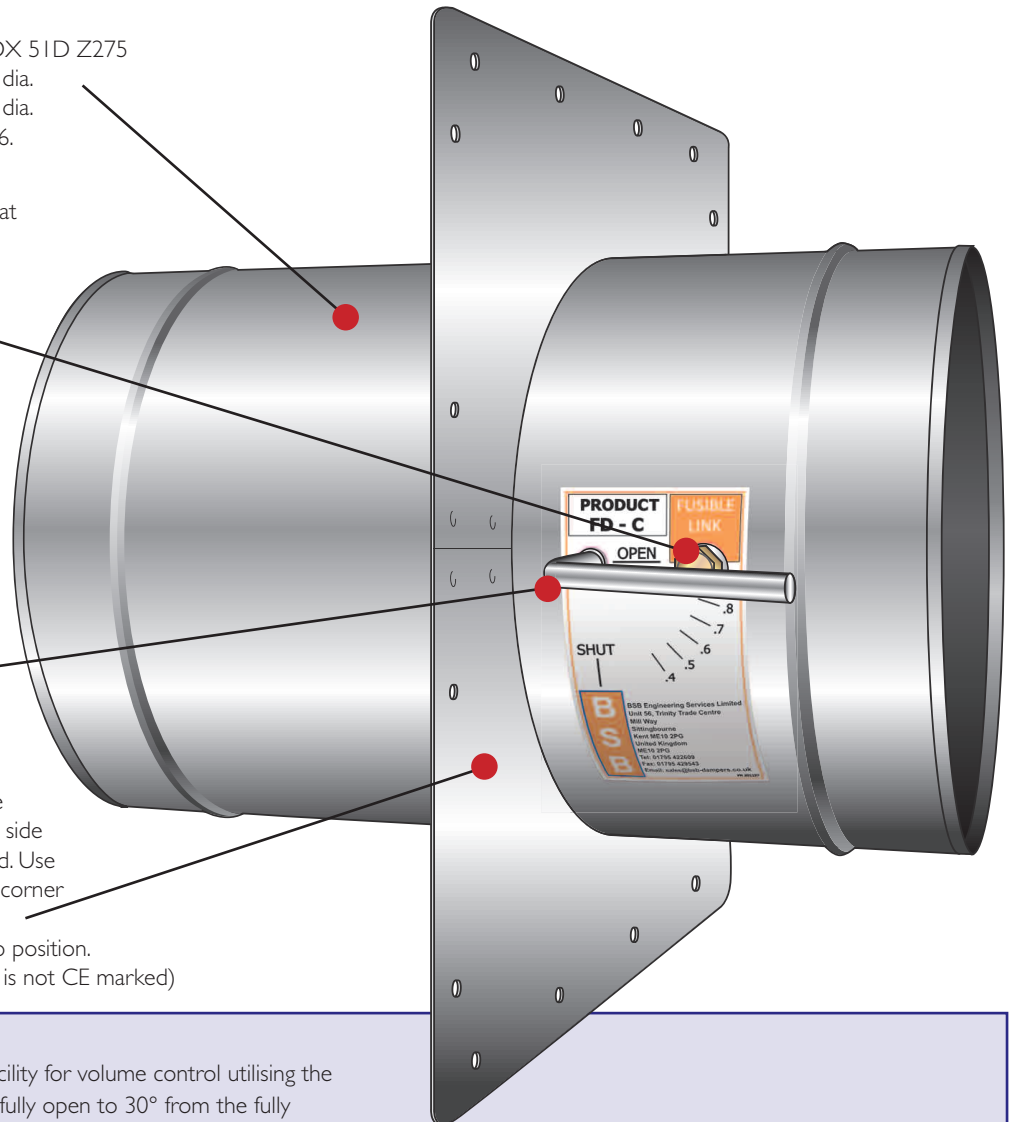

Volume Control Application

The FD-C manual damper has the facility for volume control utilising the seven presets at 10° set points from fully open to 30° from the fully closed position.

The operating handle has been designed to be in line with the blade orientation thus providing an accurate guide to the blade set or released position.

The FD-C manual damper continues to be a fully operational fire damper at these presets, and when released closed manually or through the melting of the thermal fuse meets the test criteria of EN 1366-2 as provided in the relevant test reports.

Blade Seal (patented)

Layered glass woven sheets and central intumescent disc to a patented design that allows the blade assembly to be of minimal thickness, thus minimising pressure loss, providing an effective seal to comply with EN 1366-2 achieving ES classification.

Blade

Galvanised 1.2mm one piece circular steel discs either side of the patented seal design providing a 5mm thick assembly affixed by blade brackets to the reset handle. Grade 430 stainless steel option available.

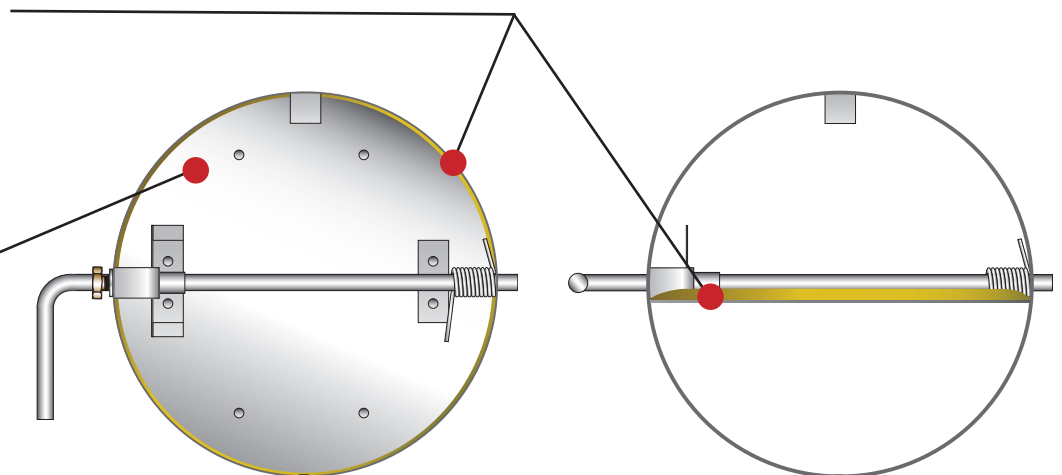

Blade Closed

Blade Open

The FD-C Series - MANUAL Operation

FD-C With Installation Plate

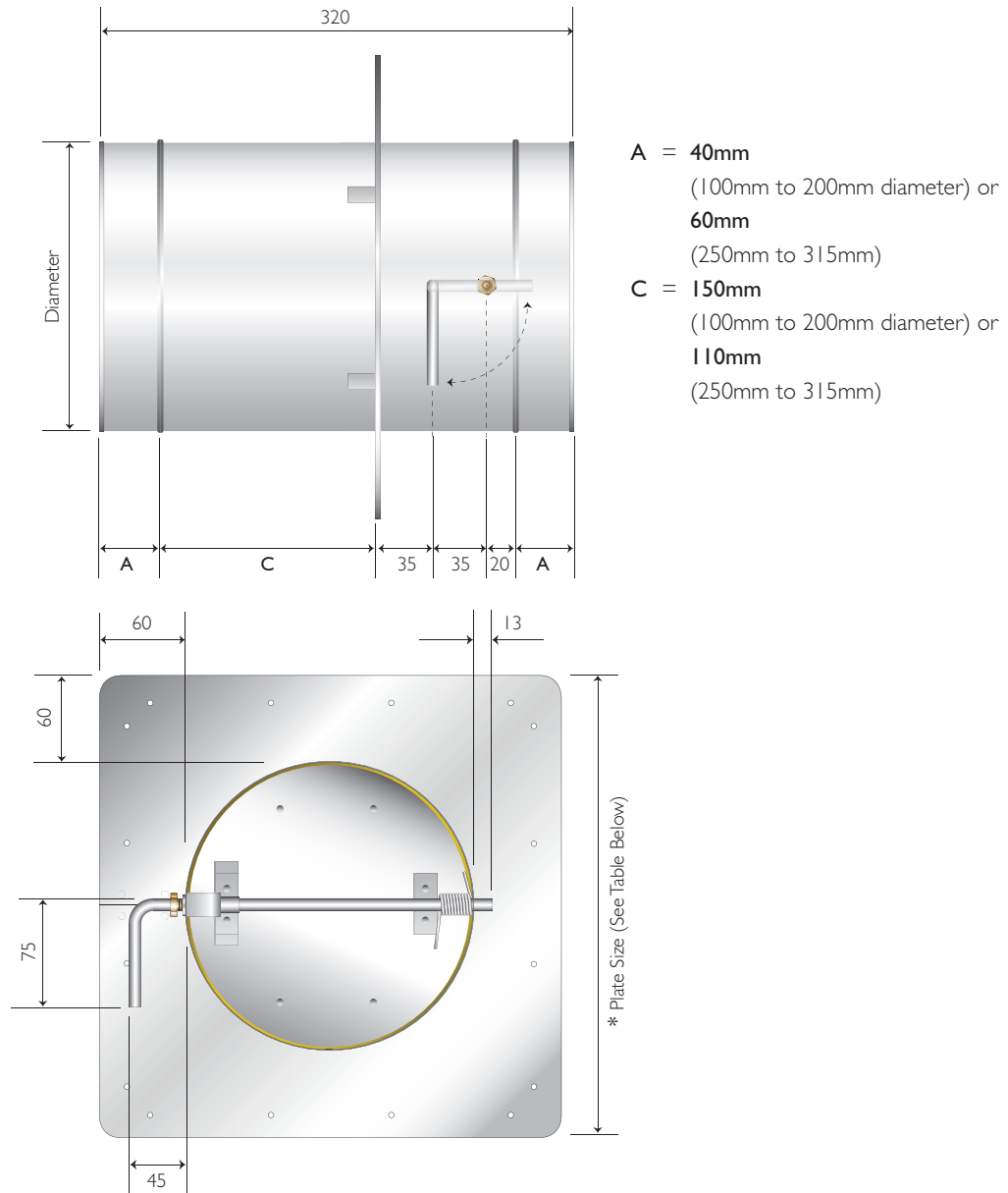

Installation Plates

NB: Use either of the two appropriate 5mm dia. corner fixing holes and all of the 5mm dia. mid span fixing holes to secure the plate into position.

Model	Dia. (mm)	Square Plate Size (mm)
FD-C100	100	220
FD-C125	125	245
FD-C150	150	270
FD-C160	160	280
FD-C200	200	320
FD-C250	250	370
FD-C300	300	420
FD-C315	315	435

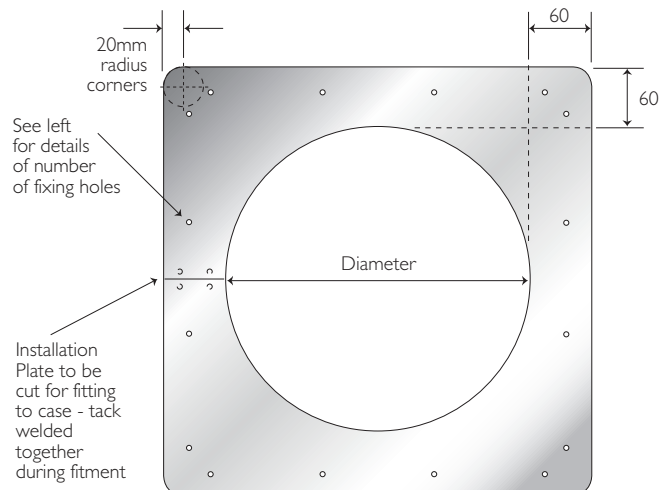

Installation Plate Detail

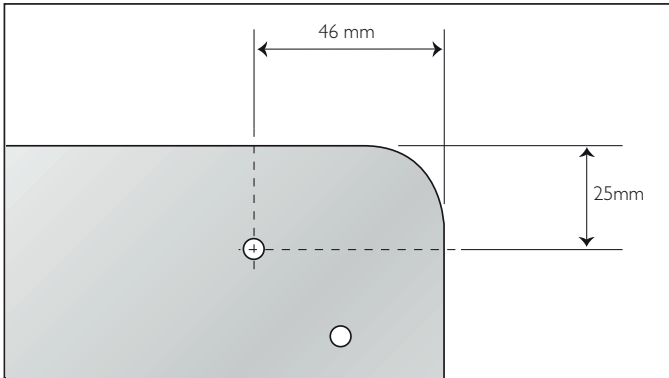

Typical Tender/Specification Text

The BSB FD-C combination Fire and Volume Control Damper shall pass the test requirements stated in EN 1366-2.

For maintenance of the integrity of compartmentation the fire damper shall have an E classification to EN 13501-3.

The damper shall have an ES classification complying with EN 1366-2 and EN 13501-3 and have a minimum ES90 rating.

Damper casings shall conform to BS EN 1506.

For the protection of escape routes and areas with sleeping risk, the FSD-C fire/smoke damper should be used. Please refer Approved Document B (ADB).

The single blade layered design shall be held open against a constant force spring that is released via a fusible link having an alloy component that melts at 72°C allowing the spring mechanism to close the damper.

The damper assembly and fusible link shall be safely tested and released closed externally to the damper without the need for specialist tools or access panels. NB: Access panels may be required to comply with DW145 G.3.1.5.

The fire damper body shall be stitch welded to meet the air tightness test requirements of HVCA specification DW144 to class A & B & C to a maximum of 1000Pa and comply with EN 1751.

The closed blade shall meet the air tightness test requirement of BS EN 1751 Class 2.

The BSB FD-C combination fire and volume control damper shall have a tested or assessed installation method that matches the requirement of the supporting construction. DW145 Method 4 Blockwork Walls, Dry Walls and Concrete Floors refers.

Leakage Classification

Blade leakage classification is given numerically 1 – 4 and case leakage classification is given using capital letters A – C of EN 1751 (sections C.2 and C.3).

The FD-C series damper meets Class 4 blade leakage section C.2 refers and Class C case leakage section C.3 of the EN 1751 standard, section C.2 refers.

Normal operating conditions - not exceeding 1000Pa, Classes A & B of DW 144 2016 Specification will apply.

Cleats

Cleats are available as an optional accessory where requested and will be provided factory fitted as given below.

The FD-C series damper must be installed as per BSB installation, operating and maintenance document to comply with CE marking. The use of cleats as the sole installation/support method will not comply with CE marking.

Installation Plate Cleats Detail

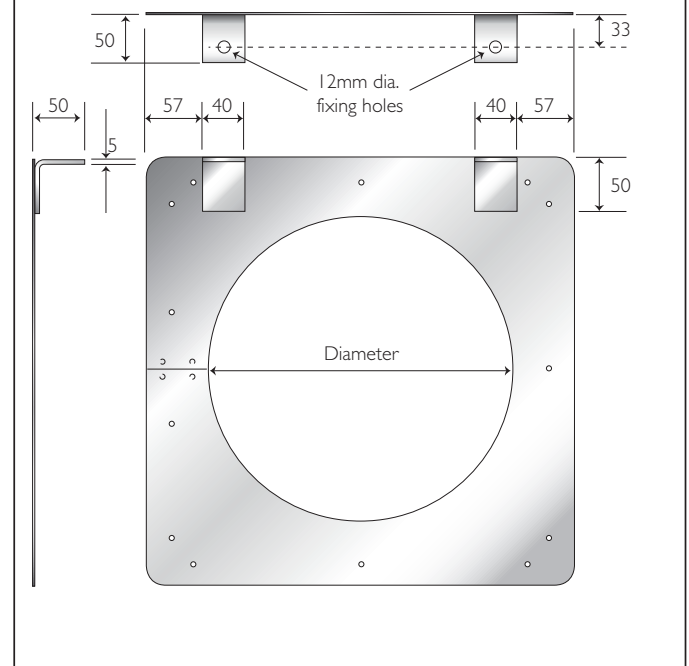

For the suitability of cleats fitted to the FD-C installation plate, local authority approval must be sought.

Where cleats are requested to be fitted and local authority approval has been given, the drop rod system will be the responsibility of others.

FD-C in Blockwork Wall - Damper as tested with Installation Plate and Handle to the inside of the furnace

Tested to BS EN 1366-2

Test Report No. 281585A refers

- Fire and Volume Control dual function
- Tested to BS EN 1366-2 and classified to BS EN 13501-3
- ES I20 integrity and leakage classification
- Complies with classes A, B & C of DWI44 and BS EN 1751

Test Conclusions:

The FD-C damper satisfied the requirements of BS EN 1366-2 and BS EN 13501-3 achieving the lowest closed blade leakage of any damper within its class.

Dampers were tested affixed to the inside of the furnace wall and also to the external wall of the furnace with the damper closed blade being fully exposed to the furnace rapid rising temperature. The achieved ES classification ensures that in a fire condition the non fire side is fully protected (from radiated heat) for the achieved period, providing vital time for the emergency services to respond, ensuring safe passage of escape and protection of contents

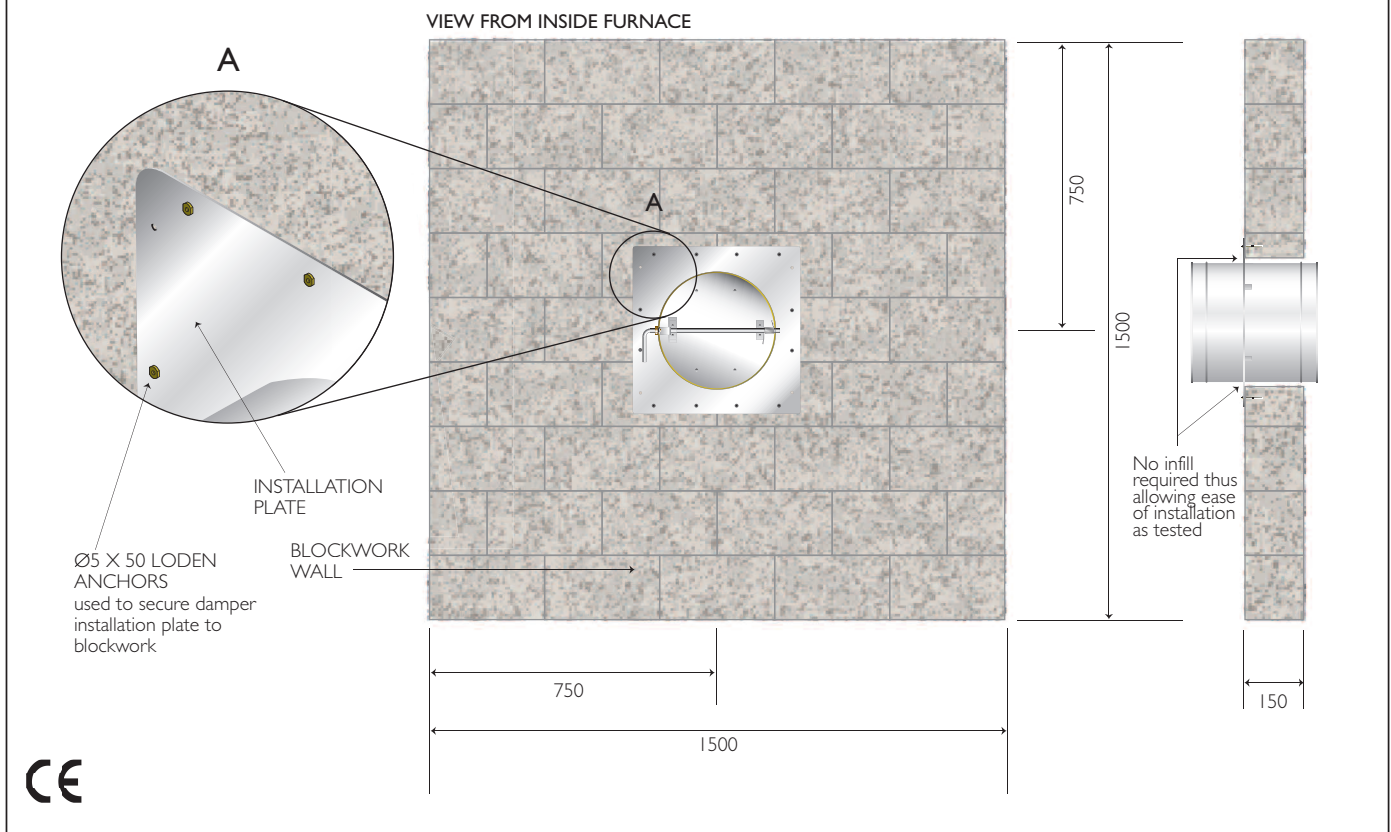

Blade Leakage Graph

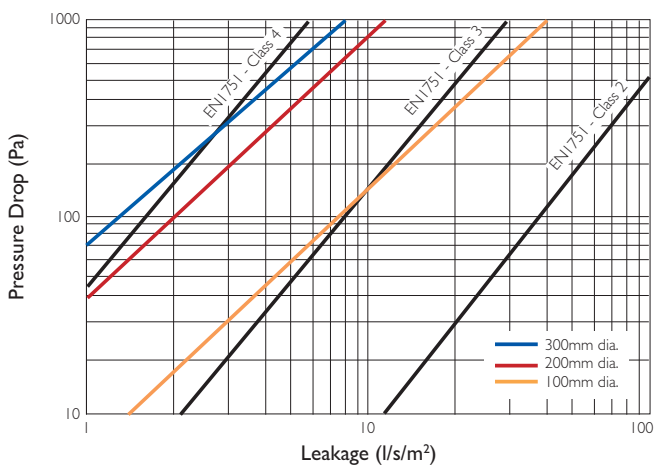

Case Leakage Graph - Model FD-C100

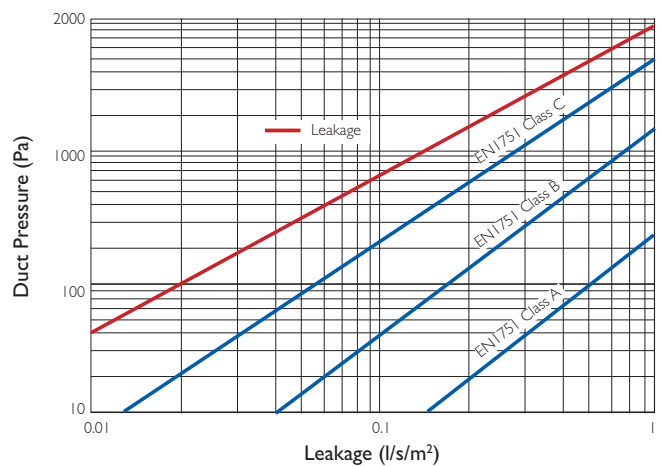

See Page 10 for Pressure Drop Graphs

FD-C in Blockwork Wall - Damper as tested with Installation Plate and Handle to the non furnace side

Tested to BS EN 1366-2

Test Report No. 276065 refers

- Fire and Volume Control dual function
- Tested to BS EN 1366-2 and classified to BS EN 13501-3
- DWI45 Method 4 refers
- ES120 integrity and leakage classification
- Complies with classes A, B & C of DWI44 and BS EN 1751

Test Conclusions:

The FD-C damper satisfied the requirements of BS EN 1366-2 and BS EN 13501-3 achieving the lowest closed blade leakage of any damper within its class. Dampers were tested affixed to the inside of the furnace wall and also to the external wall of the furnace with the damper closed blade being fully exposed to the furnace rapid rising temperature. The achieved ES classification ensures that in a fire condition the non fire side is fully protected (from radiated heat) for the achieved period, providing vital time for the emergency services to respond, ensuring safe passage of escape and protection of contents

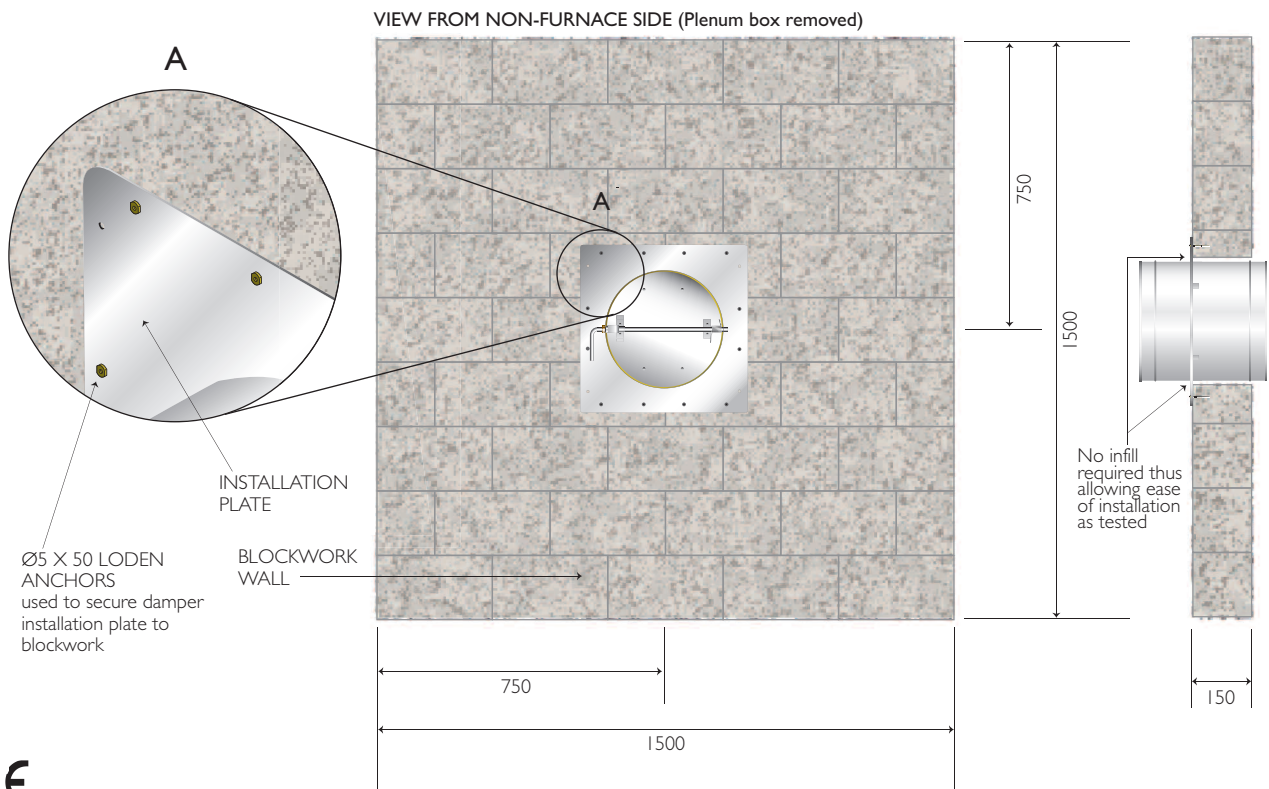

Blade Leakage Graph

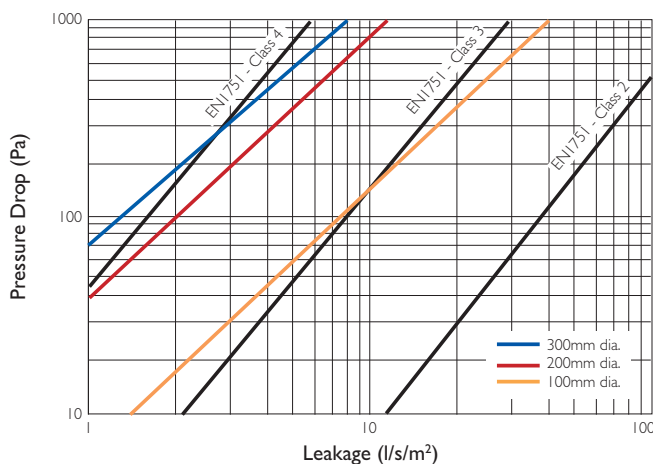

Case Leakage Graph - Model FD-C100

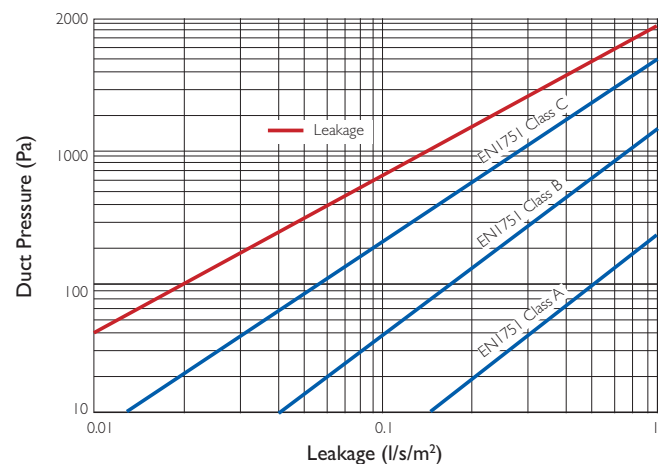

See Page 10 for Pressure Drop Graphs

FD-C in Dry Wall - Thermal fuse inside and outside of furnace

Tested to BS EN 1366-2 - Test Report No. 276643 refers

- Fire and Volume Control dual function
- Tested to BS EN 1366-2 and classified to BS EN 13501-3
- E590 integrity and leakage classification.
- Complies with classes A, B & C of DWI44.

Test Conclusions:

The FD-C damper satisfied the requirements of BS EN 1366-2 and BS EN 13501-3 achieving the lowest closed blade leakage of any damper within its class.

Dampers were tested affixed to the inside of the furnace wall and also to the external wall of the furnace with the damper closed blade being fully exposed to the furnace rapid rising temperature. The achieved ES classification ensures that in a fire condition the non fire side is fully protected (from radiated heat) for the achieved period, providing vital time for the emergency services to respond, ensuring safe passage of escape and protection of contents

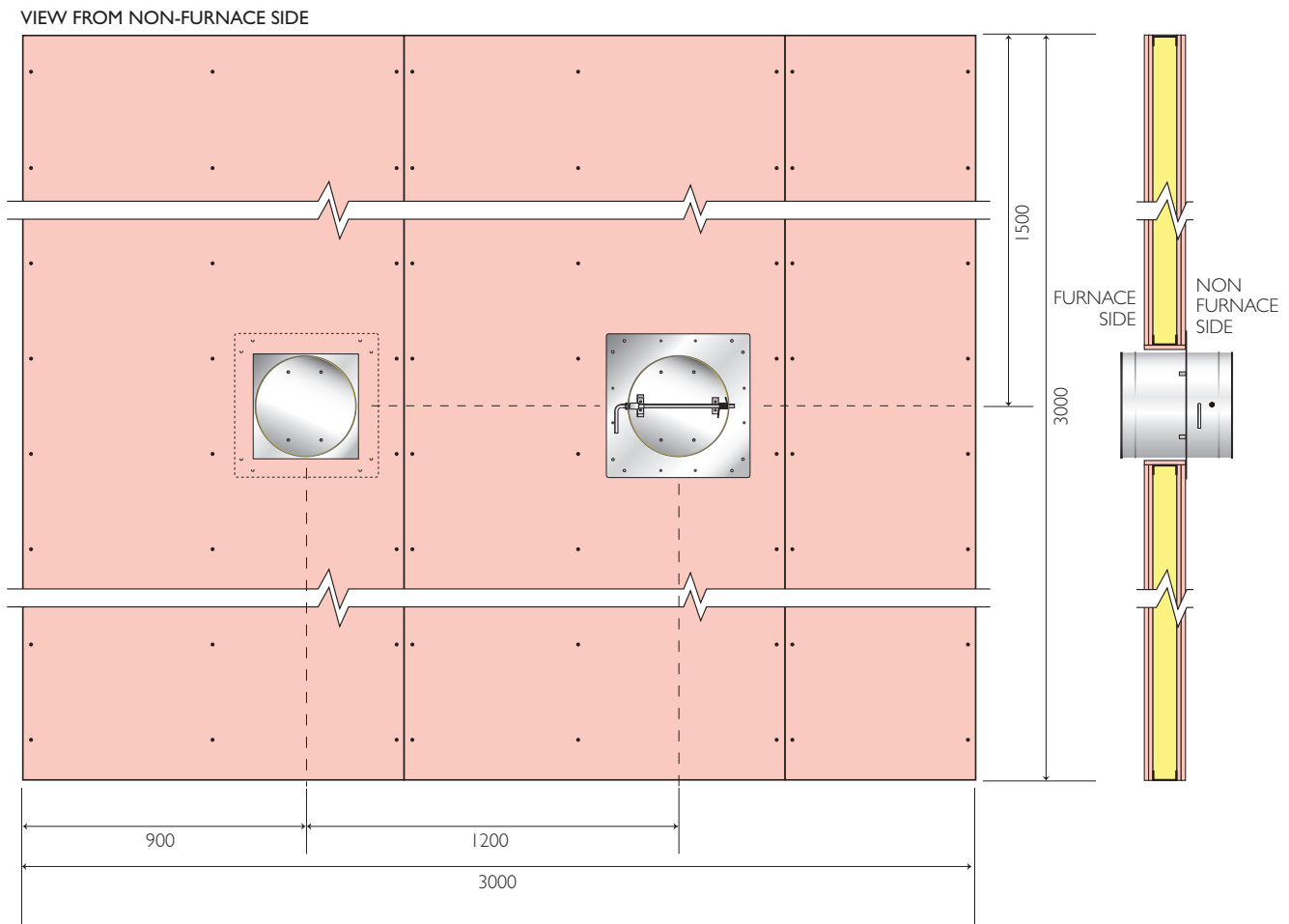

The FD-C single blade combination fire and volume control damper with its unique feature of requiring only a single installation plate when being installed within tested applications, and without the need for any infill between the damper body and the structure that it sits within. It is the first damper of its type to achieve and meet the requirements of test BS EN 1366-2 and BS EN 13501-3

FD-C in Dry Wall - Test Report No. 276643 refers
Thermal fuse outside of furnace

FD-C in Dry Wall - Test Report No. 276643 refers
Thermal fuse inside of furnace

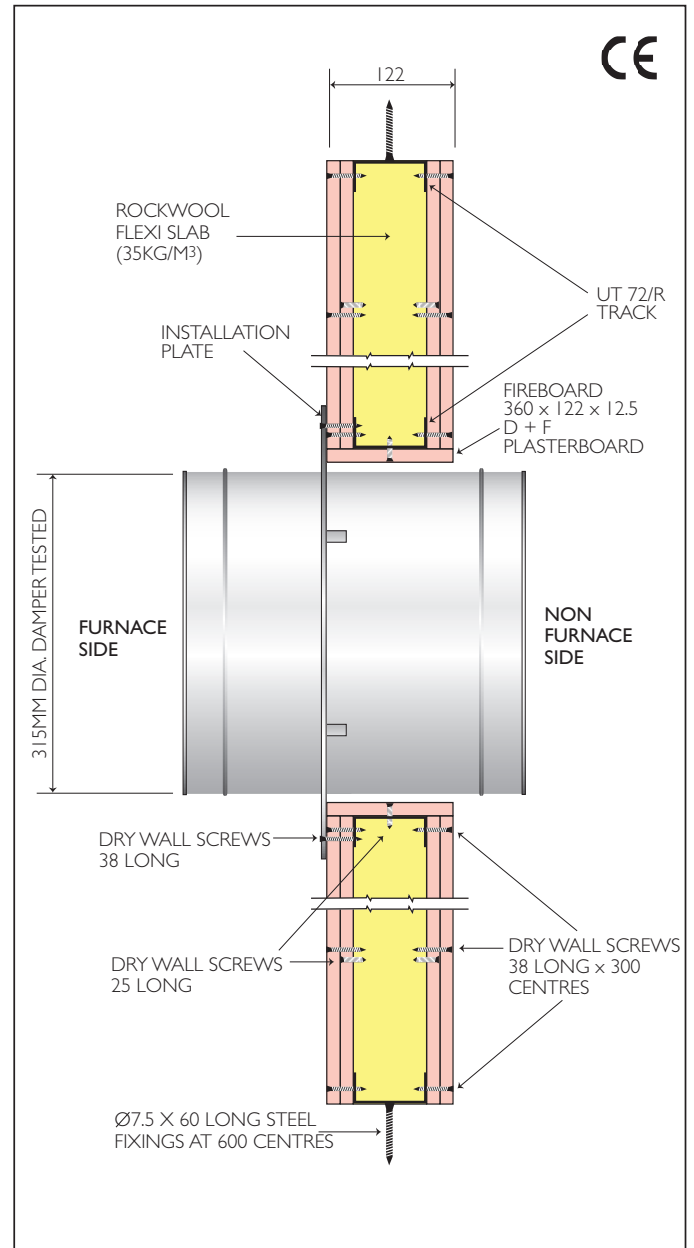
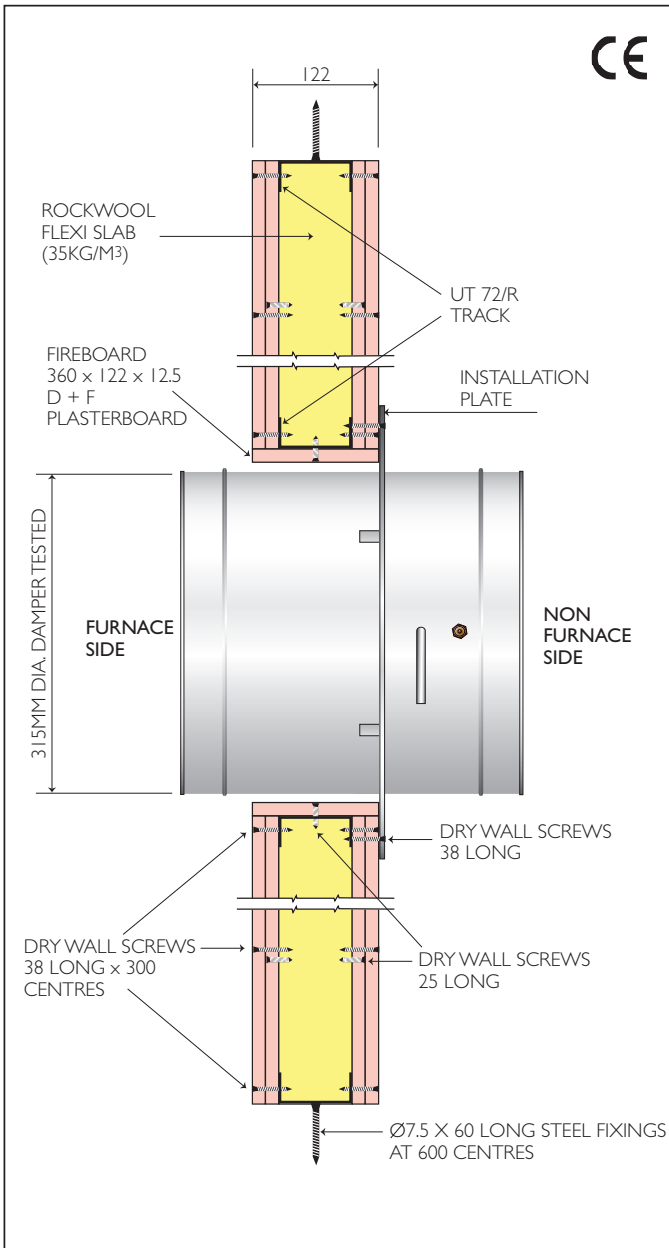

Blade Leakage Graph

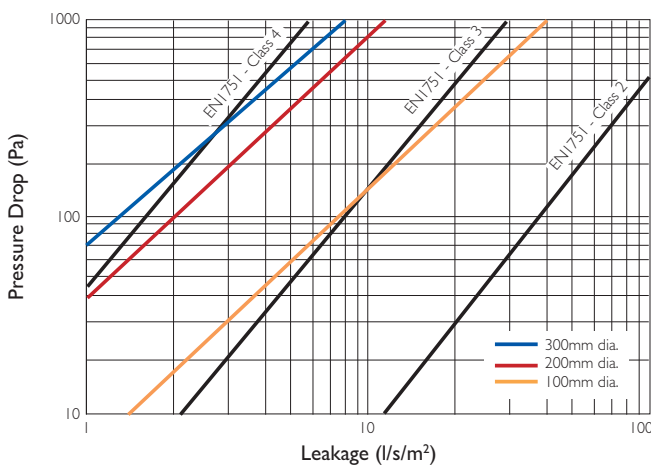

Case Leakage Graph - Model FD-C100

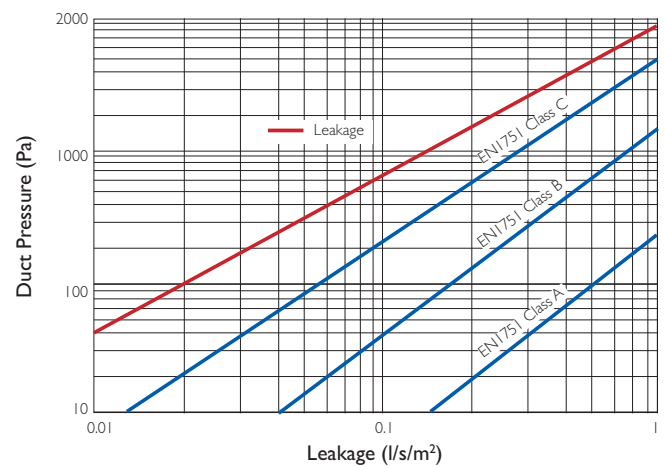

See Page 10 for Pressure Drop Graphs

Performance Data

Pressure Drop Graph - Model FD-C100

100mm diameter:

Free area = 64%

Velocity range 0 to 10 m/s

- 67.5° from open
- 45° from open
- 22.5° from open
- Fully open

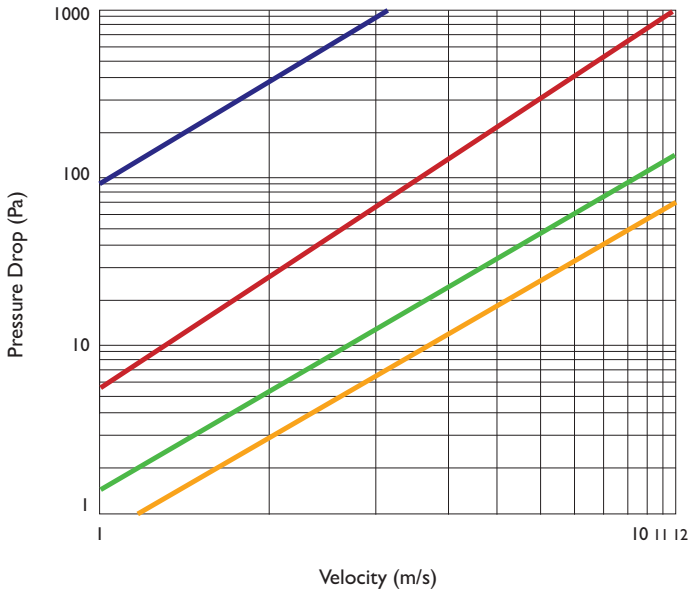

Pressure Drop Graph - Model FD-C200

200mm diameter:

Free area = 85%

Velocity range 0 to 10 m/s

- 67.5° from open
- 45° from open
- 22.5° from open
- Fully open

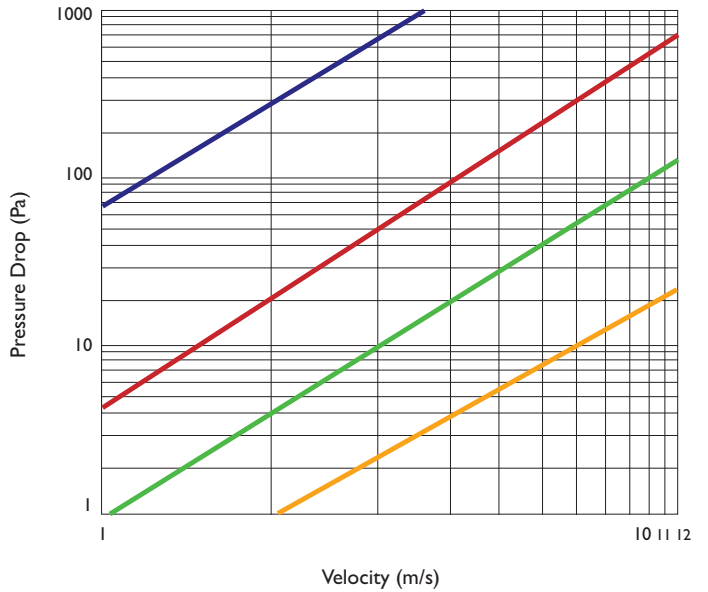

Pressure Drop Graph - Model FD-C300

300mm diameter:

Free area = 91%

Velocity range 0 to 10 m/s

- 67.5° from open
- 45° from open
- 22.5° from open
- Fully open

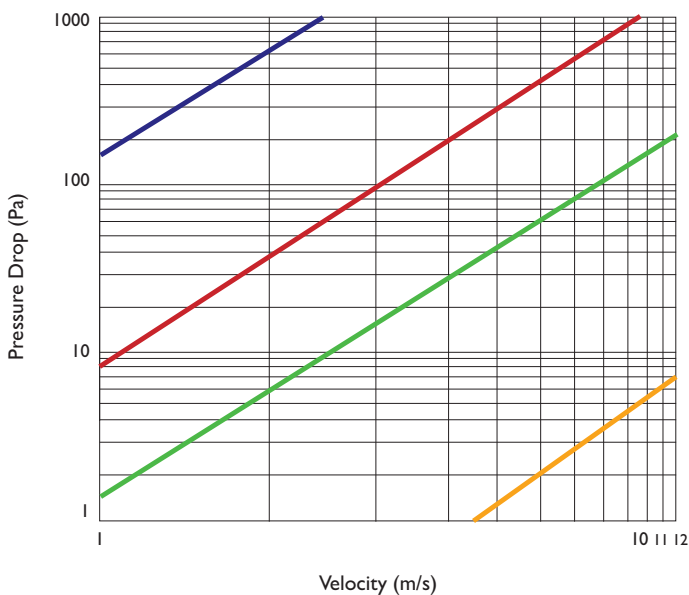

Time / Temperature Curve - EN13501-4:2007

- Standard Curve
- BRE Test 276065
- BRE Test 276066

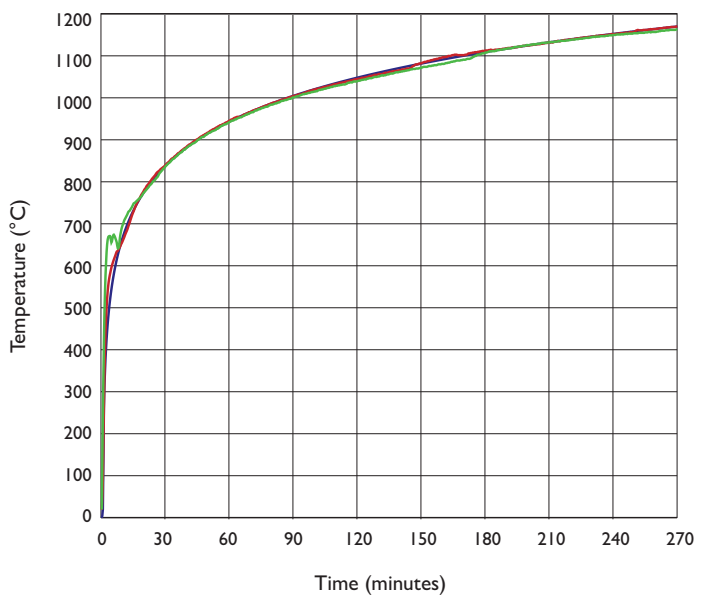

Installation Method

DW145 Method 4 - Blockwork walls
DW145 Method 4 - Dry walls

Dry Wall Screws 38mm long to affix installation plate ensuring fixing into dry lining metal frame

No infill required, thus allowing ease of installation as tested

122

Micro Switch

The factory fitted micro switch to provide remote indication of the damper blade status. The micro switch is fitted on the opposite side to the operating handle where a purpose designed cam fitted to the protruding blade operating spindle allows the release of the micro switch actuating lever, allowing the snap action contacts INO + INC to change state.

Wiring connections are made via M3, 5 terminal screw fixings.

Mechanical life: 1 million cycles

Complies with EN60204 and EN292 standards

Electrical data:

Thermal current (I_{th}): 16A
 Rated insulation voltage: 250VAC 300VDC
 Protection against short circuits: fuse 10A 500V type gG

Utilisation categories:

Alternate current: AC15 (50 ... 60Hz)			
U _e (V)	250		
I _e (A)	5		
Direct current: DC13			
U _e (V)	24	125	250
I _e (A)	4	1,1	0,4

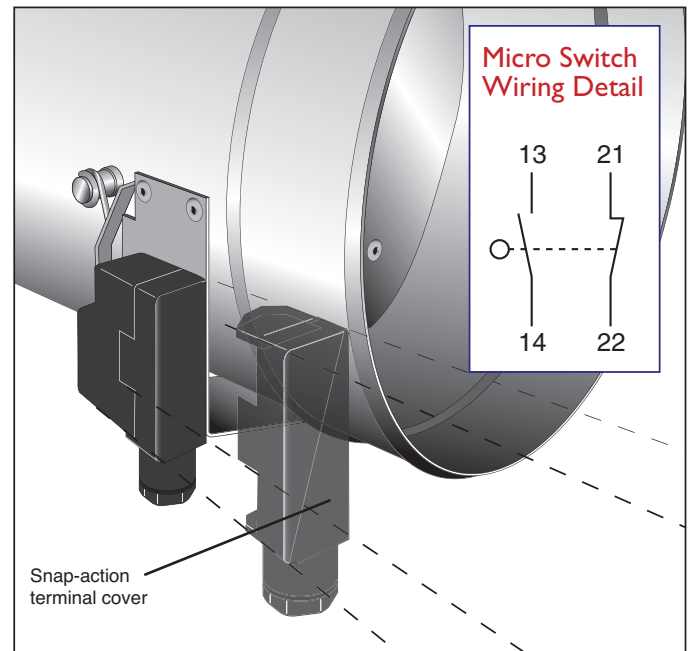

Maintenance Notes

FD-C Series dampers are designed for normal dry filtered air systems. A programme of planned inspections should be carried out to include full operational checks, correct interface with, and function of, any control systems, cleaning and light lubrication.

As a guide, this should take place on a maximum of six month intervals.

Reference should be made to BS 9999 for more information.

Records of damper installation and position shall be kept. Records of the condition of the dampers and their functionality/repair etc should be kept as these products come under the requirements of the Regulatory Reform (Fire safety) Order (RRFSO).

These inspection and maintenance programmes may need to be repeated more regularly if the dampers are exposed to inclement/dusty conditions or fresh air intakes and the frequency of such checks should be developed based on site experience.

Damper Free Area

Model	Free Area	Model	Free Area
FD-C100	64%	FD-C200	85%
FD-C125	73%	FD-C250	88%
FD-C150	79%	FD-C300	91%
FD-C160	81%	FD-C315	91%

FD-C Series

Single Blade Circular Fire Dampers – Ordering Codes



FD-C 200 G MS

FD-C Externally Resettable Circular Single Blade Damper

Diameter: _____

Blade Material _____

- G** Galvanised Mild Steel
- S** 430 Grade Stainless Steel

Accessories _____

- MS** Single Pole Micro Switch
- CL** Cleat

Air, Fire and Smoke Control Products in the BSB Range:



For full details of the complete BSB Product Range, please refer to our individual product brochures, sales office or website.

BSB Engineering Services Limited
 Unit 56, Trinity Trade Centre, Mill Way, Sittingbourne, Kent ME10 2PD, UK • Tel: +44 (0)1795 422609 • Fax: +44 (0)1795 429543
 For purchase orders and order related enquiries, please email: orders@bsb-dampers.co.uk
 For pricing, technical and general enquiries, please email: enquiries@bsb-dampers.co.uk
 Website: www.bsb-dampers.co.uk • A member of the Maico group

BSB Engineering Services Ltd. reserves the right to modify or withdraw any specification without prior notice that may result from continuous product development. The information contained within this brochure is correct at the time of going to press. (FDC-05-2017)

