

# Bend – long

# BSU 90°

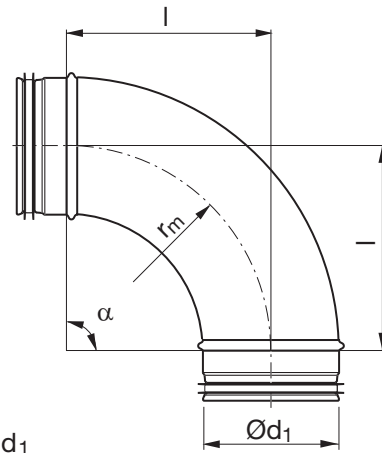

## Dimensions



$r_m \approx 1,5 \cdot d_1$

Ød <sub>1</sub> nom	l mm	m kg
100	150	0,50
125	190	0,79
150	225	0,95
160	240	1,14
180	270	1,50
200	300	1,55

## Description

Pressed and seam welded bend.

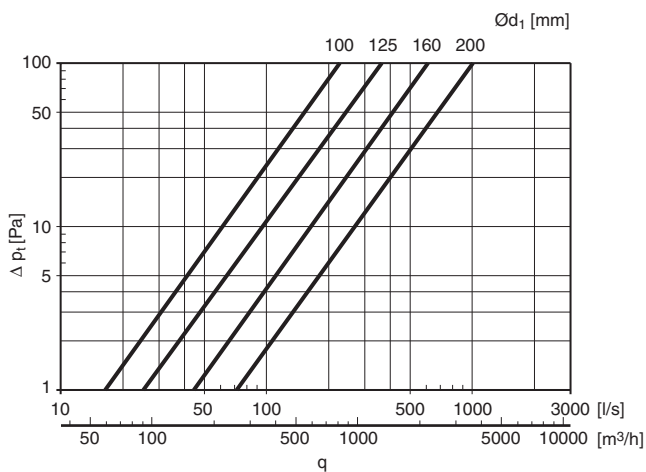

## Ordering example

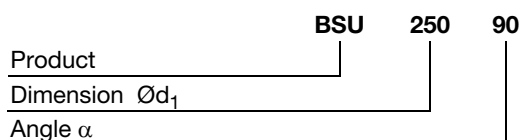

- 1
- 2
- 3
- 4
- 5
- 6
- 7
- 8
- 9
- 10
- 11
- 12
- 13
- 14
- 15
- 16
- 17
- 18