

Pressed bends BP-90



Description

Pressed bends are designed for building ventilation systems based on spiral and plain ducts. Seam welds improve the air tightness of the ventilation system, while the hemmed rim helps to avoid cutting injuries during handling and installation. The piece is connected with a duct by inserting one into the other. The pressed form of the ventilation piece helps to reduce the flow resistance and the pressure loss. Air tightness can be increased to class B by wrapping the joints with the TAL, MET or DUCT sealing tape.



There is also available version with a female end - **BPF** code or with two female ends - **BPFF** code.

Available materials - Product code example
BP-90-... - galvanized steel sheet

Product code example

Product code: **BP - aaa - 90**

type _____
 $\varnothing d_1$ _____
 angle _____

Dimensions

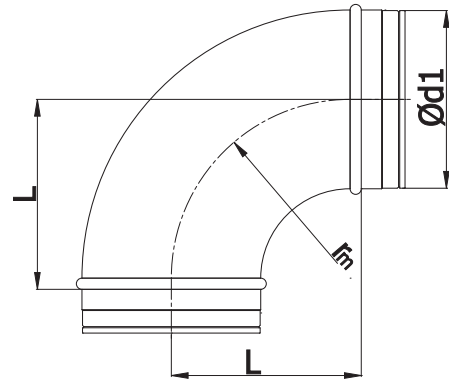

$$r_m \approx 1 \times d_1$$

$\varnothing d_{1 \text{ nom}}$ (mm)	L (mm)	Weight (kg)
80	100	0.3
100	100	0.4
125	125	0.6
140	135	0.8
150	150	0.9
160	160	1.0
180	175	1.2
200	200	1.5
250	250	2.4

Technical specifications for 90° pressed and segmented bends **BPKL/BPL/BPDL/BSKL/BSL/BSDL**

Technical specifications

Flow chart for BPKL-90/BPK-90/BPKFL-90/BPKF-90

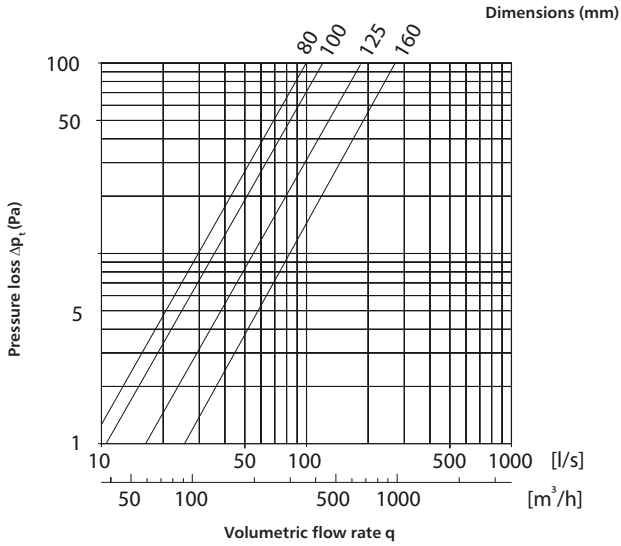

Flow chart for BSKL-90/BSK-90

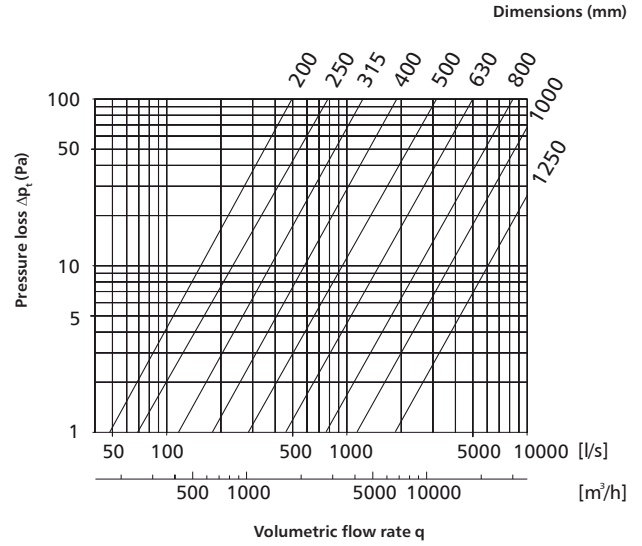

Flow chart for BPL-90/BP-90/BPL-K-90/BP-K-90

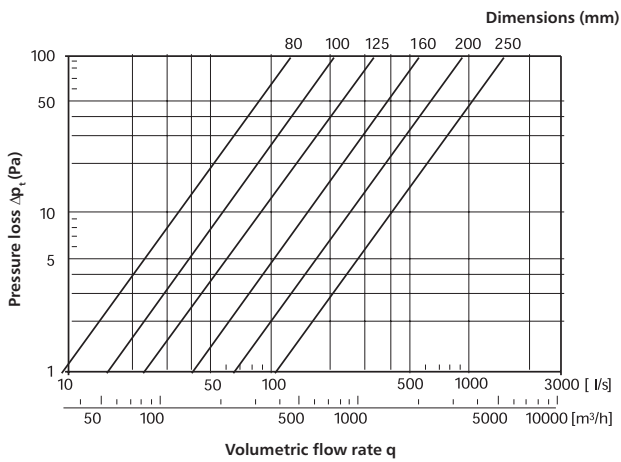

Flow chart for BSL-90/BS-90

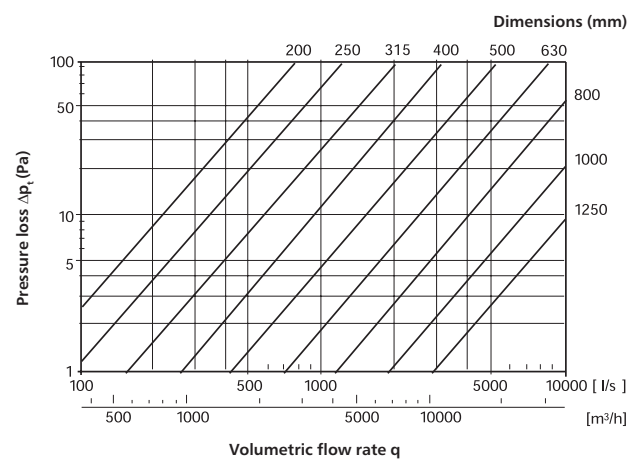

Flow chart for BPDL-90/BPD-90

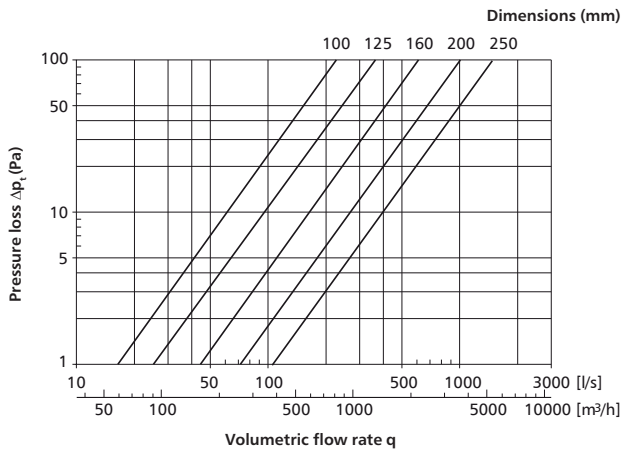

Flow chart for BSDL-90/BSD-90

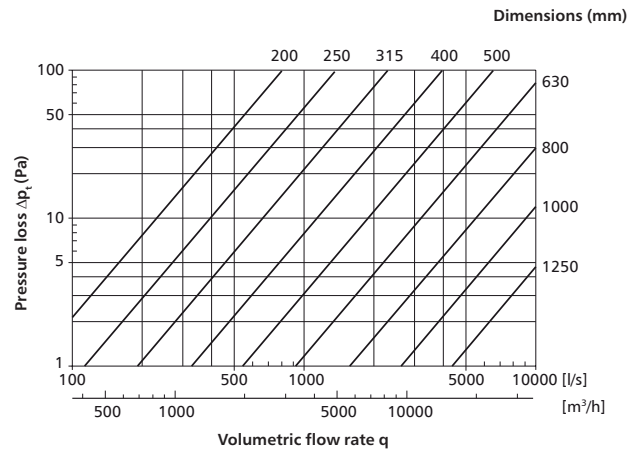

Pressed bends

BPL-60/BP-60



Description

Pressed bends are designed for building ventilation systems based on SPIRAL ducts and plain ducts. Seam welds provide air tightness class D without the need to use any other sealants. The double EPDM gasket in the BPL version provides air tightness class D according to EN 12237 for ventilation and recuperation systems. The piece is connected with a duct by inserting one into the other. The pressed form of the ventilation piece helps to reduce the flow resistance and the pressure loss. Custom bending angles of the pressed bends are available on request.



There is also available version with a female end - **BPFL** code
or with two female ends - **BPFF** code

Available materials - Product code example
BPL-...-60 - galvanized steel sheet

Product code example

Product code: **BPL - aaa - 60**

type	_____
Ød ₁	_____
angle	_____

Dimensions

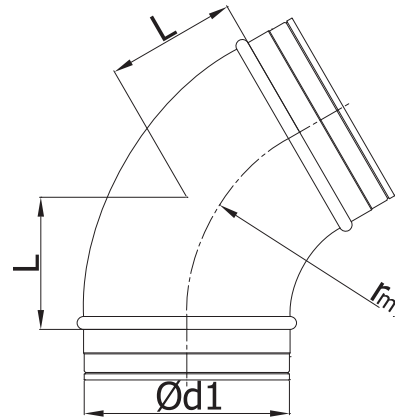

$$r_m \approx 1 \times d_1$$

Ød _{1, nom} (mm)	L (mm)	Weight (kg)
80	64	0.3
100	64	0.4
125	72	0.5
140	78	0.6
150	87	0.9
160	92	1.0
180	104	1.2
200	115	1.5
250	144	2.2

Technical specifications for 60° pressed and segmented bends

BPL/BP/BSL/BS/

Technical specifications

Flow chart for BPL-60 / BP-60

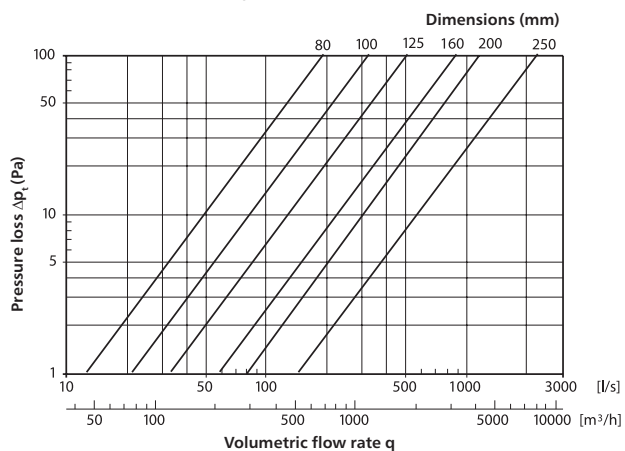

Flow chart for BPL-60 / BP-60

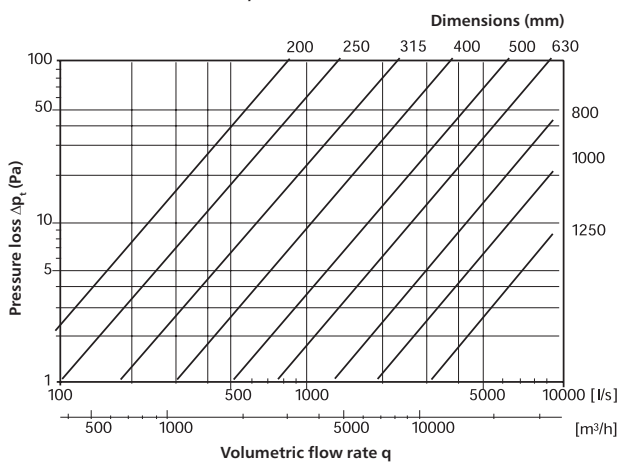

Pressed bends

BP-45



Description

Pressed bends are designed for installation of SPIRAL ducts and plain ducts. Seam welds improve the air tightness of the ventilation system, while the hemmed rim helps to avoid cutting injuries during handling and installation. The piece is connected with a duct by inserting one into the other. The pressed form of the ventilation piece helps to reduce the flow resistance and the pressure loss.



There is also available version with a female end - **BPF** code
or with two female ends - **BPFF** code

Available materials - Product code example
BP-...-45 - galvanized steel sheet

Product code example

Product code: **BP - aaa - 45**

type _____
 $\text{\O}d_1$ _____
 angle _____

Dimensions

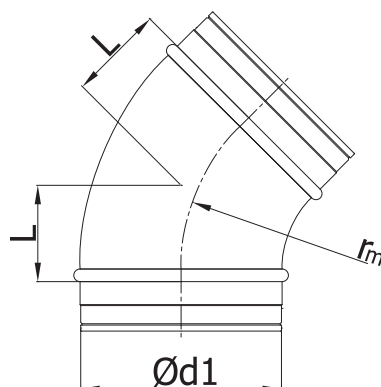

$$r_m \approx 1 \times d_1$$

$\text{\O}d_{1 \text{ nom}}$ (mm)	L (mm)	Weight (kg)
80	41	0.2
100	41	0.3
125	52	0.4
140	56	0.4
150	62	0.6
160	66	0.6
180	75	0.7
200	83	0.9
250	104	1.3

Technical specifications for 45° pressed and segmented bends **BPL/BP/BPL-K/BP-K/BPDL/BPD/BSL/BS**

Technical specifications

Flow chart for BPL-45 / BP-45

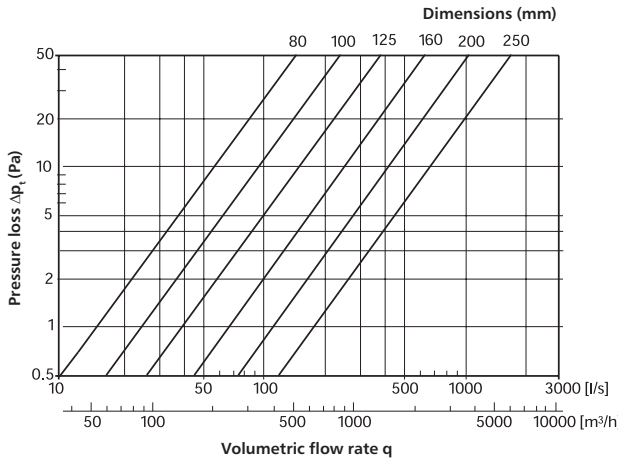

Flow chart for BSL-45 / BS-45

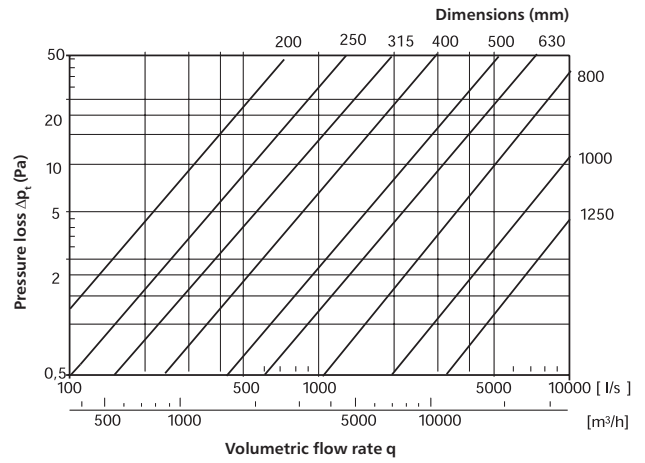

Flow chart for BPL-K-45 / BP-K-45

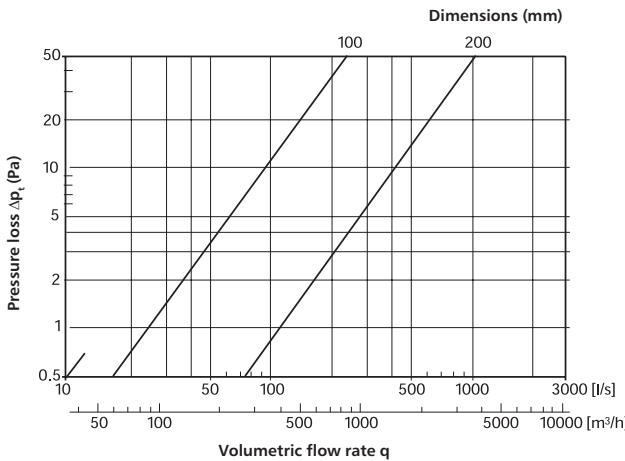

Flow chart for BPD-45 / BPD-45

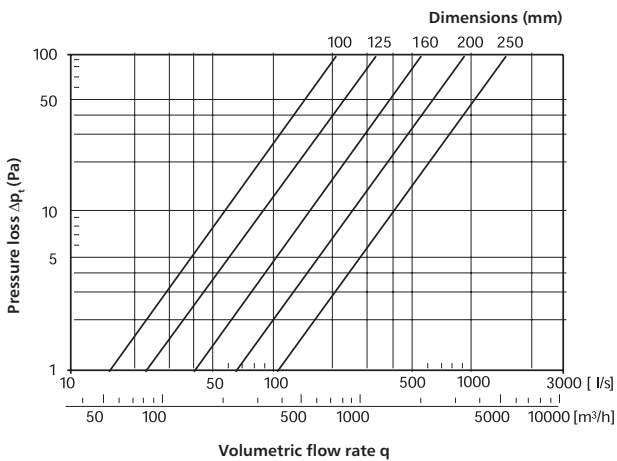

Pressed bends

BPL-30/BP-30



Description

Pressed bends are designed for installation of spiral ducts and plain ducts. Seam welds provide air tightness class D without the need to use any other sealants. The double EPDM gasket in the BPL version provides air tightness class D according to EN 12237 for ventilation and recuperation systems. The piece is connected with a duct by inserting one into the other. The pressed form of the ventilation piece helps to reduce the flow resistance and the pressure loss. Custom bending angles of the pressed bends are available on request.



There is also available version with a female end - **BPFL** code
or with two female ends - **BPFF** code.

Available materials - Product code example
BPL-30-... – galvanized steel sheet

Product code example

Product code: **BPL - aaa - 30**

type _____
 $\varnothing d_1$ _____
 angle _____

Dimensions

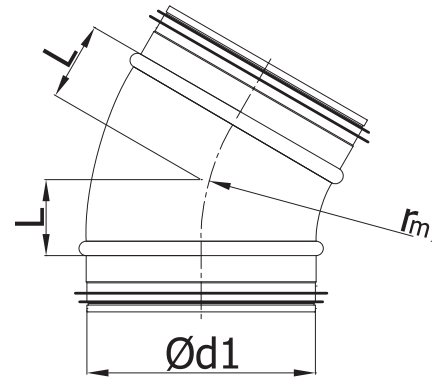

$$r_m \approx 1 \times d_1$$

$\varnothing d_{1 \text{ nom}}$ (mm)	L (mm)	Weight (kg)
80	27	0.20
100	27	0.30
125	33	0.30
140	36	0.40
150	40	0.40
160	43	0.50
180	48	0.60
200	54	0.70
250	67	1.40

Technical specifications for 30° pressed and segmented bends

BPL/BP/BSL/BS/

Technical specifications

Flow chart for BPL-30 / BP-30

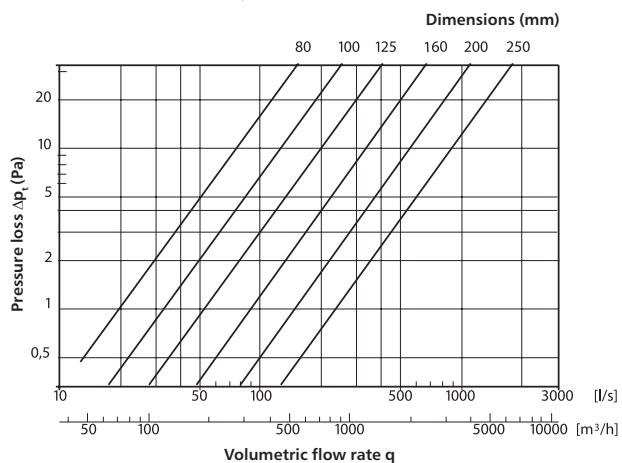

Flow chart for BSL-30 / BS-30

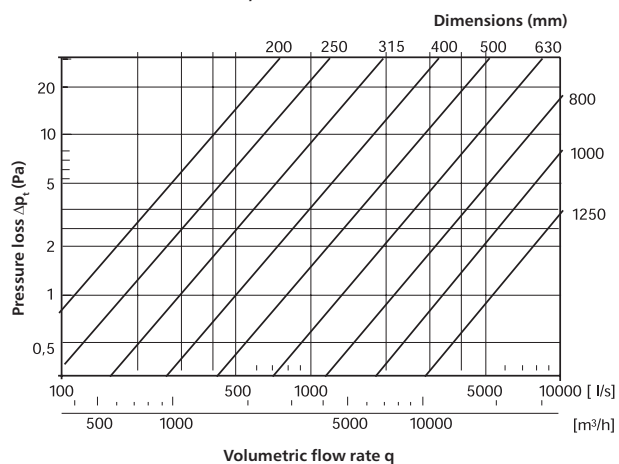

Pressed bends

BPL-15/BP-15



Description

Pressed bends are designed for installation of spiral ducts and plain ducts. Seam welds provide air tightness class D without the need to use any other sealants. The double EPDM gasket in the BPL version provides air tightness class D according to EN 12237 for ventilation and recuperation systems. The piece is connected with a duct by inserting one into the other. The pressed form of the ventilation piece helps to reduce the flow resistance and the pressure loss. Custom bending angles of the pressed bends are available on request.



There is also available version with a female end - **BPFL** code or with two female ends - **BPFF** code.

Available materials - Product code example
BPL-15-... - galvanized steel sheet

Product code example

Product code: **BPL - aaa - 15**

type _____
 $\varnothing d_1$ _____
 angle _____

Dimensions

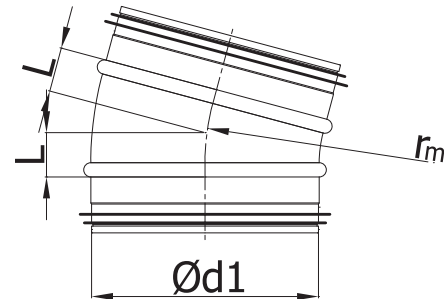

$$r_m \approx 1 \times d_1$$

$\varnothing d_{1 \text{ nom}}$ (mm)	L (mm)	Weight (kg)
80	13	0.20
100	13	0.30
112	16	0.30
125	16	0.30
140	18	0.40
150	20	0.40
160	21	0.50
180	23	0.60
200	26	0.60

Technical specifications for 15° pressed and segmented bends

BPL/BP/BSL/BS

Technical specifications

Flow chart for BPL-15 / BP-15

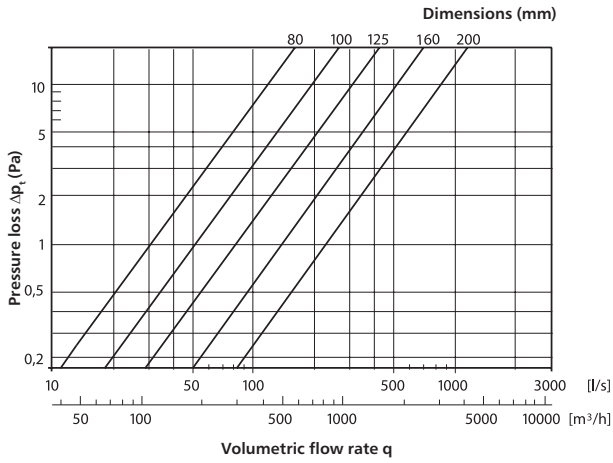

Flow chart for BSL-15 / BS-15

